



PS00007575A00

GL20-4TC Temperature Detection Module User Guide

Shenzhen Inovance Technology Co., Ltd.

Add.: Inovance Headquarters Tower, High-tech Industrial Park,
Guanlan Street, Longhua New District, Shenzhen

Tel:(0755) 2979 9595

Fax: (0755) 2961 9897

www.inovance.com



Preface

■ About this Guide

The GL20-4TC 4-channel thermocouple temperature detector module can be used with Easy series products and GL20 series communication interface modules such as GL20-RTU-ECT.

This guide describes the mechanical installation, electrical installation and programming examples of the product.

■ Standards Compliance

The following table lists the certifications, directives, and standards that the product may comply with. For details about the acquired certificates, see the certification marks on the product nameplate.

Certification	Directive		Standard
CE Certification	EMC Directive	2014/30/EU	24 VDC products EN 61131-2 220 VAC products EN 61131-2 EN 61000-3-2 EN 61000-3-3
	Low Voltage Directive (LVD)	2014/35/EU	EN 61010-1 EN 61010-2-201
	RoHS Directive	2011/65/EU amended by (EU) 2015/863	EN IEC 63000
UL/cUL Certification	-		UL 61010-1 UL 61010-2-201 UL 61010-2-030 CAN/CSA-C22.2 No. 61010-1 CSA C22.2 NO. 61010-2-201 CSA C22.2 NO. 61010-2-030

Certification	Directive	Standard
KCC Certification	-	-
EAC Certification	-	-

■ More Data

Data Name	Data Code	Description
GL20-RTU-ECT Communication Interface Module User Guide	PS00004985	This guide describes the installation, wiring and more of the product.

■ Revision History

Date	Revision	Description
February 2023	A00	First release

■ How to obtain

This guide is not in the scope of delivery. If necessary, you can download the PDF file in two ways:

- Log in to Inovance's website (www.inovance.com), choose Support > Download, search by keyword, and then download the PDF file.
- Scan the QR code with a smartphone to obtain the document.

■ Warranty Instructions

The warranty period of the product is 18 months as of the date of manufacture (refer to the barcode on the equipment). If otherwise agreed upon, the agreed terms and conditions shall prevail. After the warranty period expires, maintenance will be charged.

Within the warranty period, maintenance will be charged for damages caused by the following:

- your failure to operate the product in accordance with the user guide
- events beyond our reasonable control, such as fire, flood and abnormal voltage

- function misuse
- out-of-range application
- other events of force majeure, including but not limited to lightning, earthquake and other extreme weather events

The maintenance fee is charged according to the latest Price List of Inovance. If otherwise agreed upon, the agreed terms and conditions shall prevail.

For details, see Product Warranty Card.

Safety Precautions

■ Safety Disclaimer

1. Read and comply with the safety instructions during installation, operation, and maintenance of the equipment.
2. To ensure the safety of humans and the products, follow the marks on the products and all the safety instructions in this document.
3. "CAUTION", "WARNING", and "DANGER" items in this guide do not indicate all safety precautions that need to be followed; instead, they just supplement the safety precautions.
4. Use this product in environments meeting the design and specification requirements; otherwise, a fault may occur. Noncompliance-caused malfunction or damage to parts are not covered in product quality warranty.
5. Inovance shall take no responsibility of any personal injuries or property damages caused by improper use.

■ Safety Levels and Definitions

 **Danger**: Indicates that failure to comply with the notice will result in death or severe personal injuries.

 **Warning**: Indicates that failure to comply with the notice may result in death or severe personal injuries.

 **Caution**: Indicates that failure to comply with the notice may result in minor or moderate personal injuries or damage to the equipment. Please keep this guide well so that it can be read when necessary and forward this guide to the end user.

During Control System Design

Danger

- Provide a safety circuit outside the PLC so that the control system can still work safely once external power failure or PLC fault occurs.
- Add a fuse or circuit breaker because the module may smoke or catch fire due to long-time overcurrent caused by operation above rated current or load short-circuit.

Warning

- An emergency stop circuit, a protection circuit, a forward/reverse operation interlocked circuit, and a upper position limit and lower position limit interlocked circuit must be set in the external circuits of PLC to prevent damage to the machine.
- To ensure safe operation, for the output signals that may cause critical accidents, please design external protection circuit and safety mechanism.
- Once PLC CPU detects abnormality in the system , all outputs may be closed; however, when a fault occurs in the controller circuit, the output may not be under control. Therefore, it is necessary to design an appropriate external control circuit to ensure normal operation.
- If the PLC output units such as relays or transistors are damaged, the output may fail to switch between ON and OFF states according to the commands.
- The PLC is designed to be used in an indoor electrical environment (overvoltage category II). The power supply must have a system-level surge protector, assuring that overvoltage due to lightning shock can't be applied to the PLC's power supply input terminals, signal input terminals and output terminals, to prevent damage to the equipment.

Installation

 **Warning**

- Installation must be carried out by the specialists who have received the necessary electrical training and understood enough electrical knowledge.
- Disconnect all external power supplies of the system before removing/installing the module. Failure to do so may result in electric shock, module fault or malfunction.
- Do not use the PLC where there are dust, oil smoke, conductive dust, corrosive or combustible gases, or exposed to high temperature, condensation, wind & rain, or subject to vibration and impact. Electric shock, fire and malfunction may also result in damage or deterioration to the product.
- The PLC is open-type equipment that must be installed in a control cabinet with lock (cabinet housing protection > IP20). Only the personnel who have received the necessary electrical training and understood enough electrical knowledge can open the cabinet.

 **Caution**

- Prevent metal filings and wire ends from dropping into ventilation holes of the PLC during installation. Failure to comply may result in fire, fault and malfunction.
- Ensure there are no foreign matters on ventilation surface. Failure to comply may result in poor ventilation, which may cause fire, fault and malfunction.
- Ensure the module is connected to the respective connector securely and hook the module firmly. Improper installation may result in malfunction, fault or fall-off.

Wiring

 **Danger**

- Wiring must be carried out by personnel who have received the necessary electrical training and understood enough electrical knowledge.
- Disconnect all external power supplies of the system before wiring. Failure to comply may result in electric shock, module fault or malfunction.
- Perform good insulation on terminals so that insulation distance between cables will not reduce after cables are connected to terminals. Failure to comply may result in electric shock or damage to the equipment.

 **Caution**

- To avoid electric shock, cut off the power supply before connecting the power supply of the HMI.
- The input power of the product must meet the specifications listed in this guide. If the power input does not meet the specifications, the equipment may be damaged. Thus, check regularly that the DC power provided by the switching-mode power supply unit is stable.

During Operation and Maintenance

 **Caution**

- Maintenance & inspection must be carried out by personnel who have the necessary electrical training and experience.
- Do not touch the terminals while the power is on. Failure to comply may result in electric shock or malfunction.
- Disconnect all external power supplies of the system before cleaning the module. Failure to comply may result in electric shock.
- Disconnect all external power supplies of the system before removing the module or connecting/removing the communication wirings. Failure to comply may result in electric shock or malfunction.

Safety Recommendations

- In positions where the mechanical parts is exposed to operators, such as positions for loading and unloading machinery tools, or where the machine operates automatically,
- If modification on the program is needed during system operation, use a password or other protective measures to ensure that only authorized operators can perform such modification.

Disposal

 **Caution**

- Treat the scrapped product as industrial waste. Dispose of the battery according to local laws and regulations.
- Recycle retired equipment by observing industry waste disposal standards to avoid environmental pollution.

1 Product Information

1.1 Model Number and Nameplate

GL 20 - 4 TC

①

②

③

④

<p>① Product Information GL: General local module</p>	<p>③ I/O Points 4: 4 inputs</p>
<p>② Serial Number 20: 20 series module</p>	<p>④ Module Type TC: Thermocouple temperature detector</p>

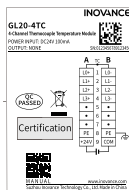





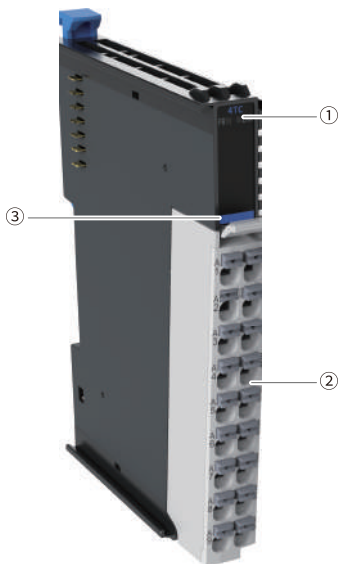

Based on the above description of model number and nameplate, the relevant ordering data of this product is described in the following table.

Model	Description	Product Code	Applicable Model
GL20-4TC	GL20 series 4-channel thermocouple temperature detector module	01440338	Easy series products and GL20 series communication interface modules such as GL20-RTU-ECT

1.2 Components



No.	Name	Definition			
①	Signal indicators	PR (POWER +RUN)	Power / running indicator	Yellow green	<ul style="list-style-type: none"> ● ON: The module is in normal operation. ● Flashing quickly: The module is addressed successfully. ● Flashing slowly: The module is powered on, but not addressed. ● OFF: The module is not powered on or is faulty.
		ERR	Error indicator	Red	ON when the module is faulty.
②	I/O terminal	4 thermocouple inputs, as defined in "3.2 Terminal Definition" on page 23			
③	Color identification		Red: Digital output		Orange: Analog output
			Grey: Digital input		Green: Analog input
			White: Communication		Blue: Other module

Note

- Flashing quickly: on for 200 ms followed by off for 200 ms.
- Flashing slowly: on for 200 ms followed by off for 1000 ms.

1.3 Technical Specifications

■ General Specifications

Item	Specification
Rated bus input voltage	5 VDC (4.75 V DC to 5.25V DC)
Rated bus input current	100 mA (typical@5 V)
Rated terminal input voltage	24 VDC (20.4 V DC to 28.8 VDC)
Rated terminal input current	100 mA (typical@5 V)
Rated terminal output voltage	/
Rated terminal output current	/
Hot swap	Not supported
Anti-reverse connection 24 V	Supported
Dimensions (W x H x D)	12 mm x 100 mm x 75 mm
Weight	About 157 g

■ Input Specifications

Item	Specification
Input channels	4
Digital resolution	24 bits
Display sensitivity	0.1°C, 0.1°F
Input terminal	Thermocouple input, thermocouple type: B, E, N, J, K, R, S, T
Compensation method	Internal cold junction compensation
Accuracy (room temperature 25°C)	$(\pm 0.1\%)^{[1]}$ ($\pm 100\text{mV}$ full scale) + cold junction compensation error ^[2]
Accuracy (operating temperature -20°C to 55°C)	$(\pm 0.3\%)^{[1]}$ ($\pm 100\text{mV}$ full scale) + cold junction compensation error ^[2]
Isolation	Isolation between I/O terminals and power supply, no isolation between channels
Input action display	/

Item	Specification
Input derating	/
Overlimit and wire break detection	Supported
Power consumption	<0.9 W

*[1]: Indicates ADC sampling accuracy, which needs to be determined based on sensor type and thermocouple detection temperature range. For details, see [“Table 1-1” on page 13](#).

*[2]: The cold junction compensation error needs to be determined based on the mounting direction, adjacent module type and operating temperature range. For details, see [“Table 1-2” on page 15](#).

■ Software Specifications

Item	Specification
Diagnostic report configuration	Supported
Diagnostic detection configuration	Supports overlimit and wire break detection
Sensor type configuration	Supported thermocouple types: B, E, N, J, K, R, S, T, default type K thermocouple
Filter time	0s to 100s (configurable through software, default 5s)
Overflow and overflow detection	Supports reporting overflow errors only when overflow is enabled.
Overlimit detection configuration	Supported
Independent channel configuration	Supported
Temperature drift configuration	Supported
Temperature setting range	-204.8 to +204.7 temperature units
Sampling cycle	250 ms, 500 ms, 1000 ms/4 channels
Display mode	Celsius (°C), Fahrenheit (°F)
Sensitivity	0.1°C, 0.1°F

Item	Specification
Sampling refresh	Refresh asynchronously according to the sampling time, not required to refresh synchronously according to the bus cycle
Stop mode	Output at maximum value, no longer refreshed
Wire break or overlimit	Output at maximum value, no longer refreshed
System diagnostics	System power exception
Channel diagnostics	Beyond upper limit alarm, beyond lower limit alarm, wire break alarm, overflow error
Software diagnostics	Not supported
Configuration diagnostics	Configuration error identification, channel parameter configuration error

■ Accuracy Calculation

Within the operating temperature range and when the temperature change rate is less than 0.3°C/min, the accuracy of the product = ADC sampling accuracy + cold junction compensation error. According to the measurement principle, the module should be powered on for 45 minutes before measurement.

- Recommended: Within the operating temperature range and when installed upright horizontally (refer to “Figure 2-1” on page 20), when the adjacent module is a temperature module, the cold junction compensation error is within $\pm 3^{\circ}\text{C}$.
- Not recommended: The adjacent module consumes more than 3.5W power, such as GL20-3232ETN module.

Table 1-1 Thermocouple detection range and ADC sampling accuracy

Sensor Type	Detection range	ADC Sampling Accuracy
B	200.0°C to 1800.0°C, 392.0°F to 3272.0°F	$\geq \pm 5^{\circ}\text{C}@200^{\circ}\text{C} \leq T \leq 400^{\circ}\text{C}$ $< \pm 5^{\circ}\text{C}@400^{\circ}\text{C} \leq T \leq 750^{\circ}\text{C}$ $< \pm 3^{\circ}\text{C}@750^{\circ}\text{C} \leq T \leq 1200^{\circ}\text{C}$ $< \pm 3.5^{\circ}\text{C}@1200^{\circ}\text{C} \leq T \leq 1800^{\circ}\text{C}$
E	-270.0°C to 1000.0°C, -454.0°F to 1832.0°F	$\geq \pm 1^{\circ}\text{C}@-270 \leq T \leq -200$ $< \pm 1^{\circ}\text{C}@-200 \leq T \leq 400$ $< \pm 1.5^{\circ}\text{C}@400^{\circ}\text{C} \leq T \leq 1000^{\circ}\text{C}$

Sensor Type	Detection range	ADC Sampling Accuracy
N	-200.0°C to 1300.0°C, -328.0°F to 2372.0°F	$< \pm 2^{\circ}\text{C} @ -200^{\circ}\text{C} \leq T \leq -150^{\circ}\text{C}$ $< \pm 1.5^{\circ}\text{C} @ -150^{\circ}\text{C} \leq T \leq 750^{\circ}\text{C}$ $< \pm 0.2\%$ of displayed value @ $750^{\circ}\text{C} \leq T \leq 1300^{\circ}\text{C}$
J	-210.0°C to 1200.0°C, -346.0°F to 2192.0°F	$\geq \pm 1^{\circ}\text{C} @ -210^{\circ}\text{C} \leq T \leq -100^{\circ}\text{C}$ $< \pm 1^{\circ}\text{C} @ -100^{\circ}\text{C} \leq T \leq 500^{\circ}\text{C}$ $< \pm 0.2\%$ of displayed value @ $500^{\circ}\text{C} \leq T \leq 1200^{\circ}\text{C}$
K	-270.0°C to 1370.0°C, -454.0°F to 2498.0°F	$< \pm 1.5^{\circ}\text{C} @ -270^{\circ}\text{C} \leq T \leq -200^{\circ}\text{C}$ $< \pm 1.5^{\circ}\text{C} @ -200^{\circ}\text{C} \leq T \leq -100^{\circ}$ $< \pm 1^{\circ}\text{C} @ -100^{\circ}\text{C} \leq T \leq 500^{\circ}\text{C}$ $< \pm 0.2\%$ of displayed value @ $500^{\circ}\text{C} \leq T \leq 1300^{\circ}\text{C}$ $\geq \pm 2.6^{\circ}\text{C} @ 1300^{\circ}\text{C} \leq T \leq 1370^{\circ}\text{C}$
R	-50.0°C to 1765.0°C, -58.0°F to 3209.0°F	$\geq \pm 4^{\circ}\text{C} @ -50^{\circ}\text{C} \leq T \leq 0^{\circ}\text{C}$ $< \pm 4^{\circ}\text{C} @ 0^{\circ}\text{C} \leq T \leq 250^{\circ}\text{C}$ $< \pm 2^{\circ}\text{C} @ 250^{\circ}\text{C} \leq T \leq 500^{\circ}\text{C}$ $< \pm 3.5^{\circ}\text{C} @ 500^{\circ}\text{C} \leq T \leq 1700^{\circ}\text{C}$ $\geq \pm 3.5^{\circ}\text{C} @ 1700^{\circ}\text{C} \leq T \leq 1765^{\circ}\text{C}$
s	-50.0°C to 1765.0°C, -58.0°F to 3209.0°F	$\geq \pm 4^{\circ}\text{C} @ -50^{\circ}\text{C} \leq T \leq 0^{\circ}\text{C}$ $< \pm 4^{\circ}\text{C} @ 0^{\circ}\text{C} \leq T \leq 250^{\circ}\text{C}$ $< \pm 2^{\circ}\text{C} @ 250^{\circ}\text{C} \leq T \leq 500^{\circ}\text{C}$ $< \pm 3.5^{\circ}\text{C} @ 500^{\circ}\text{C} \leq T \leq 1700^{\circ}\text{C}$ $\geq \pm 3.5^{\circ}\text{C} @ 1700^{\circ}\text{C} \leq T \leq 1765^{\circ}\text{C}$
T	-270.0°C to 400.0°C, -454.0°F to 753.0°F	$\geq \pm 1^{\circ}\text{C} @ -270^{\circ}\text{C} \leq T \leq -200^{\circ}\text{C}$ $< \pm 1^{\circ}\text{C} @ -200^{\circ}\text{C} \leq T \leq 400^{\circ}\text{C}$

Table 1-2 Cold junction compensation error

Installation Direction	Adjacent Module Type	Cold junction compensation error (-20°C to 0°C)	Cold Junction compensation error (0°C to 55°C)
Horizontal, upright	Temperature module	±3°C	±1.75°C
	Non-temperature module	±6.5°C	±4.5°C
Non-horizontal, upright	Temperature module	±5.5°C	±4°C
	Non-temperature module	±5.5°C	±4.5°C

1.4 Environmental Specifications

Item	Specification
Operating temperature	-20°C to 55°C
Operating humidity	10% to 90% RH (condensation)
Working environment	No corrosive and flammable gas and no excessive conductive dust
Storage temperature	-40°C to 70°C (<90% RH, non-condensing)
Maximum altitude	≤2000 m
Pollution degree	2 or less
Immunity	2 kV on power supply line (IEC 61000-4-4)
Overvoltage category	I
EMC immunity level	Zone B, IEC61131-2

Item	Specification
Vibration resistance	IEC 60068-2-6 5 Hz to 8.4 Hz, 3.5 mm, 8.4 Hz to 150 Hz, 1 g, 10 times each in X, Y and Z directions
Shock resistance	IEC 60068-2-27 150 m/s ² , 11 ms, 3 times each in ±X, ±Y and ±Z directions, 18 times in total

2 Mechanical Installation

2.1 Mounting Dimensions

■ Module

The mounting dimensions (in mm) are shown in the figure below.

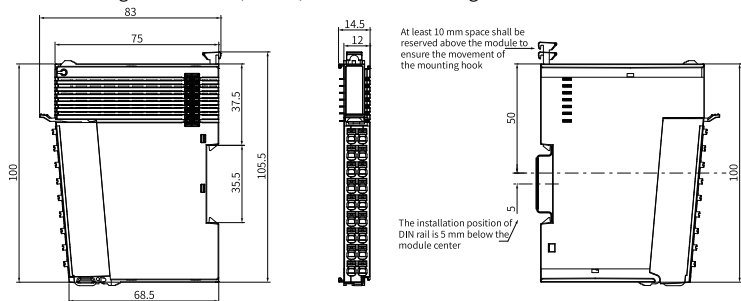

■ Cable Connection

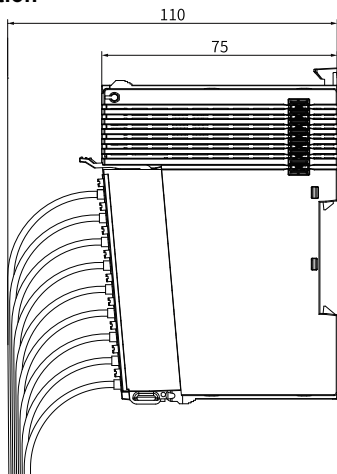

2.2 Installation Method

The module is mounted onto a DIN rail in conformity with IEC 60715 (width: 35 mm, thickness: 1 mm). The dimensions (unit: mm) are shown below.

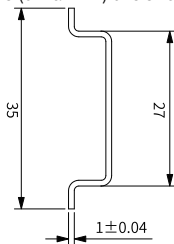

Caution

When installed on a DIN rail other than the recommended one (especially the one whose thickness is not 1.0 mm), the module will not fit in place as the mounting hook does not work.

■ Installing Modules Side-by-Side

You can install multiple modules side by side with the help of top and bottom guides on the modules, as shown below.

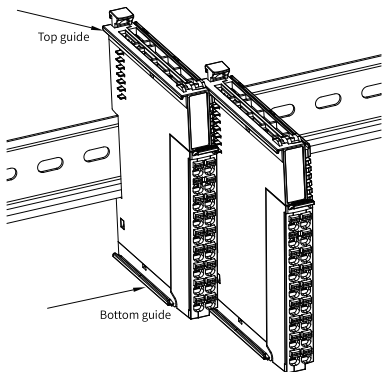

■ Installing Module onto DIN Rail

1. Align the module with the DIN rail and push the module in the direction indicated by the arrow until you hear a clicking sound, as shown below.

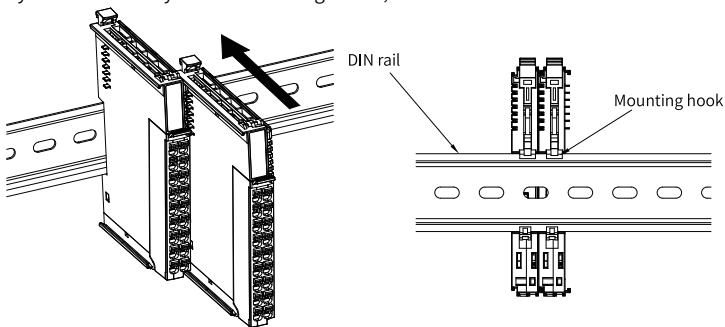

2. Make sure the DIN rail mounting hook of the module is locked. The locked and unlocked states of the mounting hook are shown below.

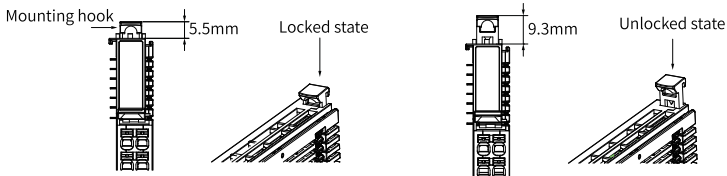

- If the mounting hook is pressed down, it is locked.
- If the mounting hook is lift up, it is unlocked.

Press down the mounting hook so lock the module to the DIN rail.



Caution

Keep the mounting hook locked when the module is not mounted on the rail. If the mounting hook is kept unlocked for an extended period of time, it may malfunction.

3. Mount an end plate on either side of the module assembly, as shown below.

To mount the end plate, hook the bottom of it to the bottom of the DIN rail, rotate the end plate to hook the top of it to the top of the DIN rail, and then tighten the screw to lock the end plate in place.

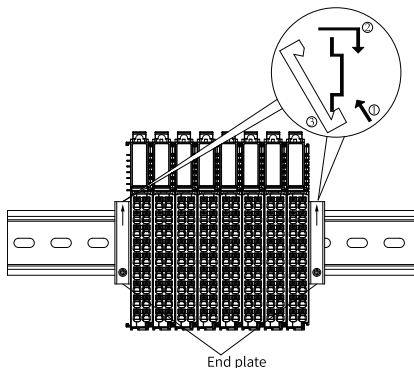
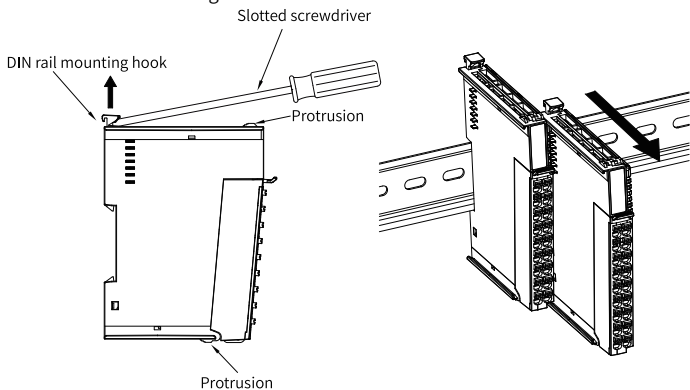

Figure 2-1 Installing end plate

■ Removing Module

Pry the DIN rail mounting hook upwards with a tool such as slotted screwdriver, hold the protrusions and pull the module out straight forward, and then press down the top of the DIN rail mounting hook.



3 Electrical Installation

3.1 Cable Selection

The cable lug and cross sectional area of the cable listed in the following table are for reference only.

Material Name	Applicable Cable Diameter		KST		Suzhou Yuanli	
	mm ²	AWG	Model	Crimping Tool	Model	Crimping tool
Tubular lug	0.3	22	E0308	KST2000L	0308	YAC-5
	0.5	20	E0508		0508	
	0.75	18	E7508		7508	
	1.0	18	E1008		1008	
	1.5	Sixteen	E1508		1508	

If you use other types of tubular lug, crimp the lug to the cables according to the shape and dimension requirements shown in the figure below.

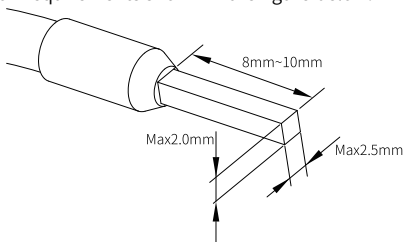

3.2 Terminal Definition



Left Signal	Left Terminal	Right Terminal	Right Signal
L0+	A1	B1	L0-
L1+	A2	B2	L1-
L2+	A3	B3	L2-
L3+	A4	B4	L3-
•	A5	B5	•
•	A6	B6	•
•	A7	B7	•
PE	A8	B8	PE
24 V +	A9	B9	COM

3.3 Terminal Wiring

■ Cautions for Wiring

- Do not bundle the extension cable together with power cables (high voltage, large current) which produce strong interference signals; otherwise, it may be influenced by noise, surge and induction. Separate it from other cables and avoid cabling in parallel.
- Select recommended cables and pinboards for connection. It is recommended that shielded cables be used as extension cables to enhance capacity of resisting interference.
- Apply single-point grounding for the shielding of shielded cable and solder sealed cable.

■ External Wiring

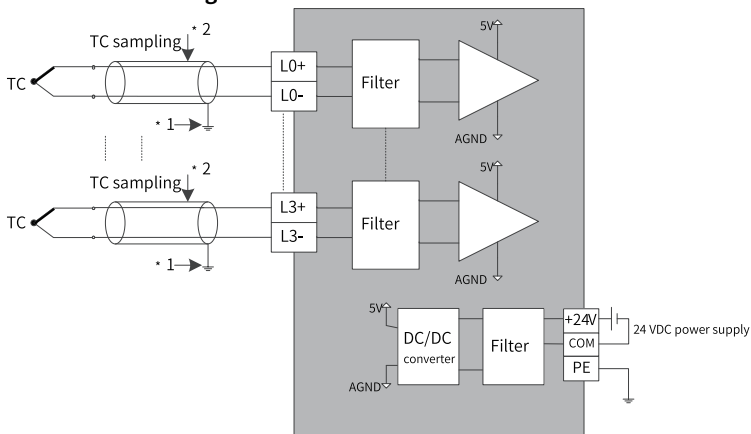

- *1 The cable must use a shielded compensating lead. It is recommended to connect the shield to PE.
- *2 Compensation leads are required when thermocouples need to be extended; otherwise, temperature measurements may be abnormal.

4 Programming Examples

The following takes input channels 0, 1, 2, 3 of the GL20-4TC module as an example, with AM600 as the main control module.

1. Right-click GL20_RTU_ECT and select Add Device, then select GL20-4TC and click Add Device.

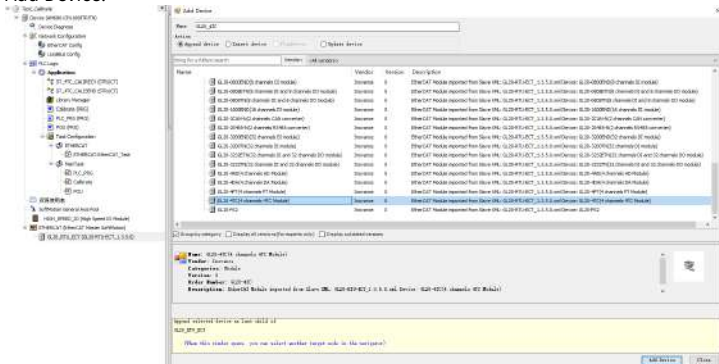

2. Double-click the GL20-4TC module, select the temperature unit and sampling cycle in the Generic Configuration section. In the Channels Config section, select the sensor type.

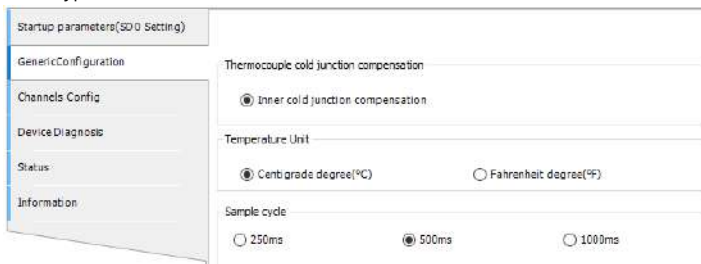

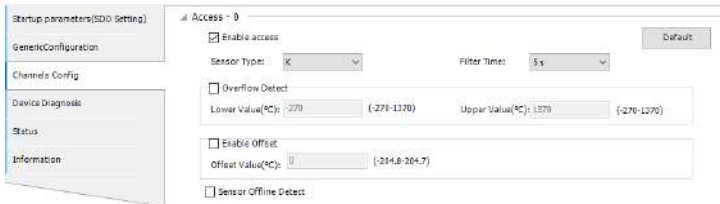

3. Add custom input variables GL20_4TC_CHI0, GL20_4TC_CHI1, GL20_4TC_CHI2, and GL20_4TC_CHI3.

ID	Scope	Name	Address	Data type	Initialization	Persistent	Constant	Comment	Attributes
1	VAR	GL20_4TC_CHI0		REAL		<input type="checkbox"/>	<input type="checkbox"/>		
2	VAR	GL20_4TC_CHI1		REAL		<input type="checkbox"/>	<input type="checkbox"/>		
3	VAR	GL20_4TC_CHI2		REAL		<input type="checkbox"/>	<input type="checkbox"/>		
4	VAR	GL20_4TC_CHI3		REAL		<input type="checkbox"/>	<input type="checkbox"/>		
5	VAR	GL20_4TC_Value0		REAL		<input type="checkbox"/>	<input type="checkbox"/>		
6	VAR	GL20_4TC_Value1		REAL		<input type="checkbox"/>	<input type="checkbox"/>		
7	VAR	GL20_4TC_Value2		REAL		<input type="checkbox"/>	<input type="checkbox"/>		
8	VAR	GL20_4TC_Value3		REAL		<input type="checkbox"/>	<input type="checkbox"/>		

4. Map the input variables GL20_4TC_CHI0, GL20_4TC_CHI1, GL20_4TC_CHI2, and GL20_4TC_CHI3 to the input channels of the configured module to complete variable mapping.

Variable	Mapping	Channel	Address	Type	Default	Unit	Description
Device control		Device ...	%QI01	UINT			Device control
LBUS status		LBUS st...	%SI02	LBINT			LBUS status
Fault ID		Fault ID	%SI03	UINT			Fault ID
Application.POU.GL20_4TC_CHI0		GL20_4...	%SD0	REAL			GL20_4TC 4TC CH0
Application.POU.GL20_4TC_CHI1		GL20_4...	%SD1	REAL			GL20_4TC 4TC CH1
Application.POU.GL20_4TC_CHI2		GL20_4...	%SD2	REAL			GL20_4TC 4TC CH2
Application.POU.GL20_4TC_CHI3		GL20_4...	%SD3	REAL			GL20_4TC 4TC CH3

5. Define the input variables with LD programming language.

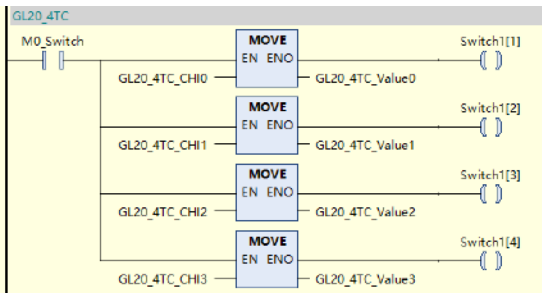

6. After successful compiling, download the project and run it.