

Product Extension HiflexDRIVE

NEW

The HiflexDrive range will be extended in the lower torque range by the **BK08**.



Gearbox BK08

- Torque 200 Nm
- Ratios 4,44 - 102,5

Gearbox BK17

- Torque 330 Nm
- Ratios 4,54 - 108,6

Motors

- Power rating 0,18 kW ... 3,0 kW
- Efficiency Classes w/o, IE1 through IE4
- Mains supply 110 V ... 690 V, 50/60 Hz
- Enclosure IP 65 (Standard), IP 67 / IP 69K (Optional)

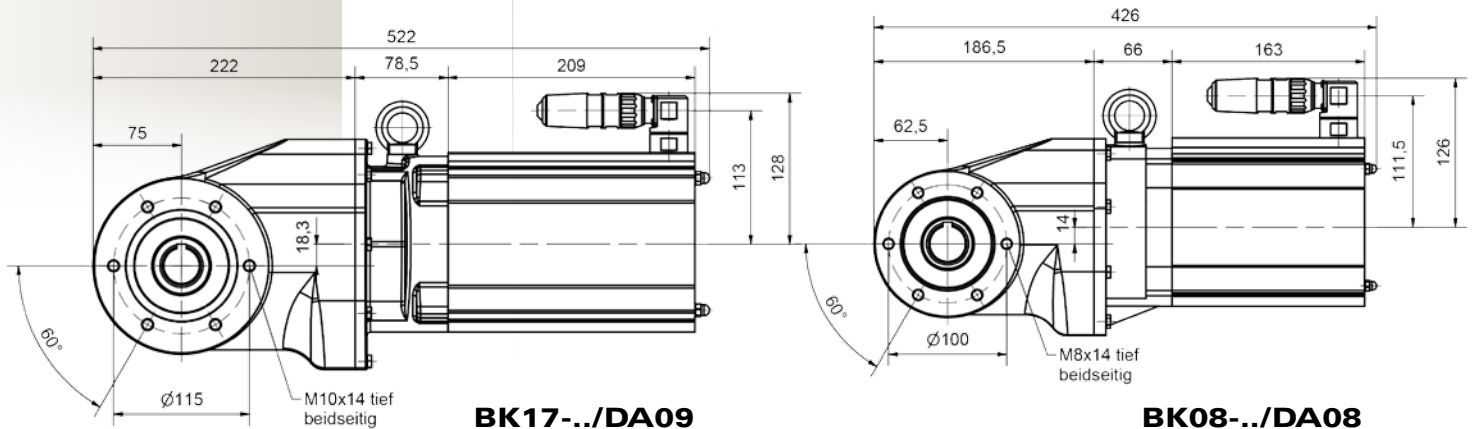

HiflexDRIVE

The Concept

Gear Solutions

Our Performance

Variance in Materials

- Housing
Aluminium and Stainless Steel
- Shafts
Steel and Stainless Steel

Diversity in Mounting

- Standard design with C-Face
- Optional A-Flange available
- Flexible shaft diameters
- All prevalent shaft types

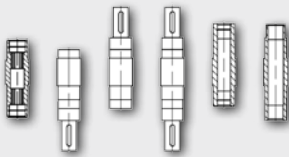

Well thought-through gear design

- No interference contour
- Form and radius adapted to the logistic industry
- Easy to clean
- Special aseptic coating
- Modular set-up

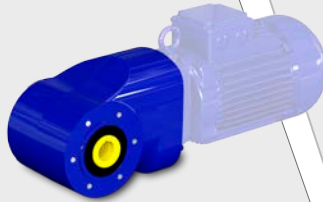

Flexibility

Adaptability

Motor Solutions

Our Performance

Motor technologies

- Asynchronous technology
- Efficiency Class IE1 to IE3
- Permanentmagnet technology (PSM)
- Efficiency class IE4
- Optimised for partial load acc. to EN 50598

Diversity in dimensioning

- Finely graded brake sizes
- Speed feedback
- Duty cycles S1 to S9
- Optimised for inverter duty
- Connection technology
- Cage Clamp
- Terminal Board
- Stainless Steel Connector

Well thought-through motor design

- Variance in housing design
- Easy to clean
- Special aseptic coating
- Modular set-up
- Flexible connection technology
- All enclosures incl. IP 69K

